

SECTION 1: Answer **one** question from this section.

Question 1

A model of a sports stadium is shown in orthographic views on the right. A pictorial illustration of the model is required.

(a) Use corner **X** as a starting point to:

- (i) draw a 1:10 scale isometric view of the model of the sports stadium; [11]
- (ii) enhance the appearance of your illustration with thick and thin lines. [3]

Estimate any dimensions not given.

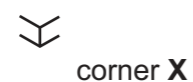
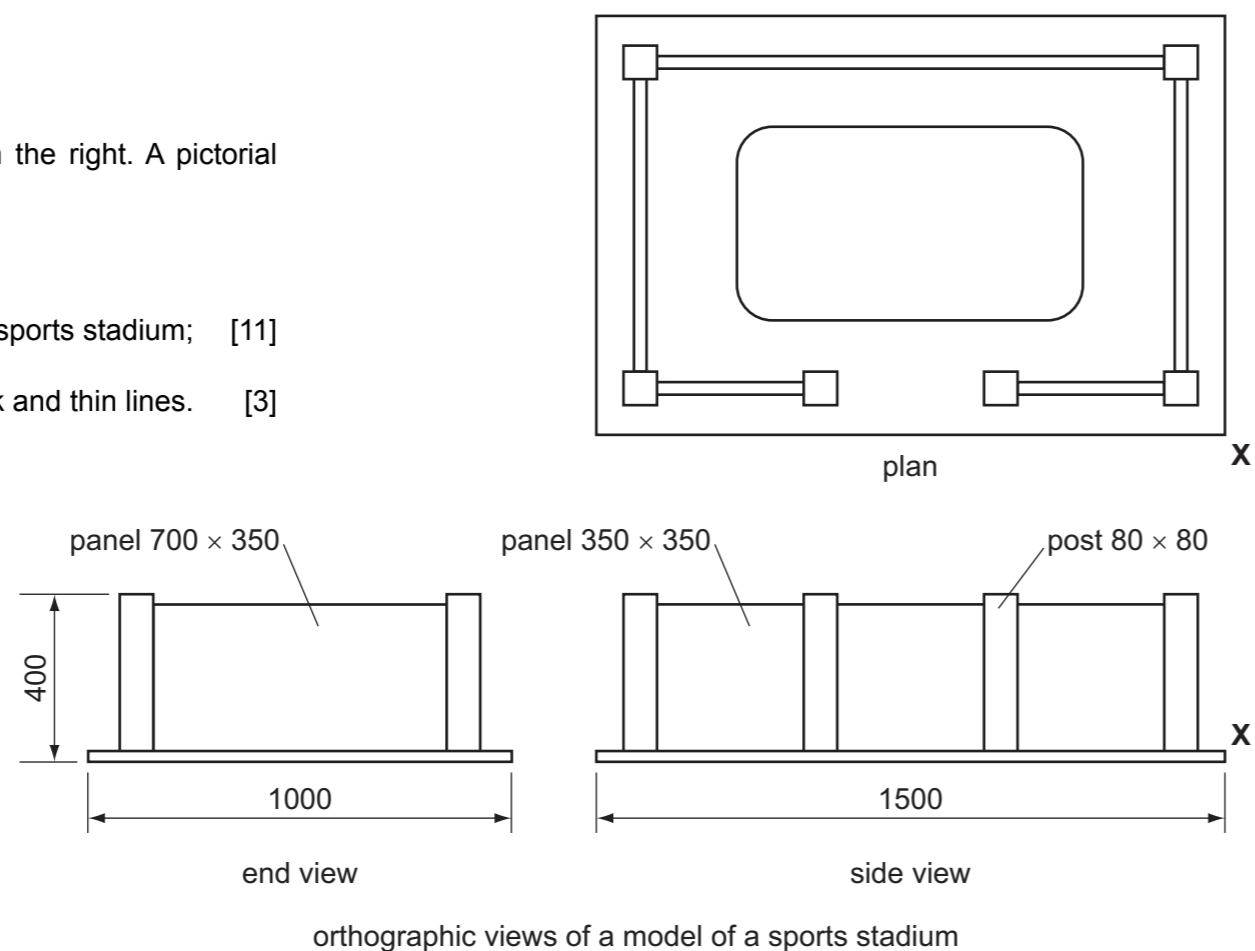

(b) A sketch of a design for the entrance to the sports stadium is shown on the right. Complete the full size drawing below by adding:

- (i) the semi-ellipse; [6]
- (ii) the word WELCOME in a central position. [2]

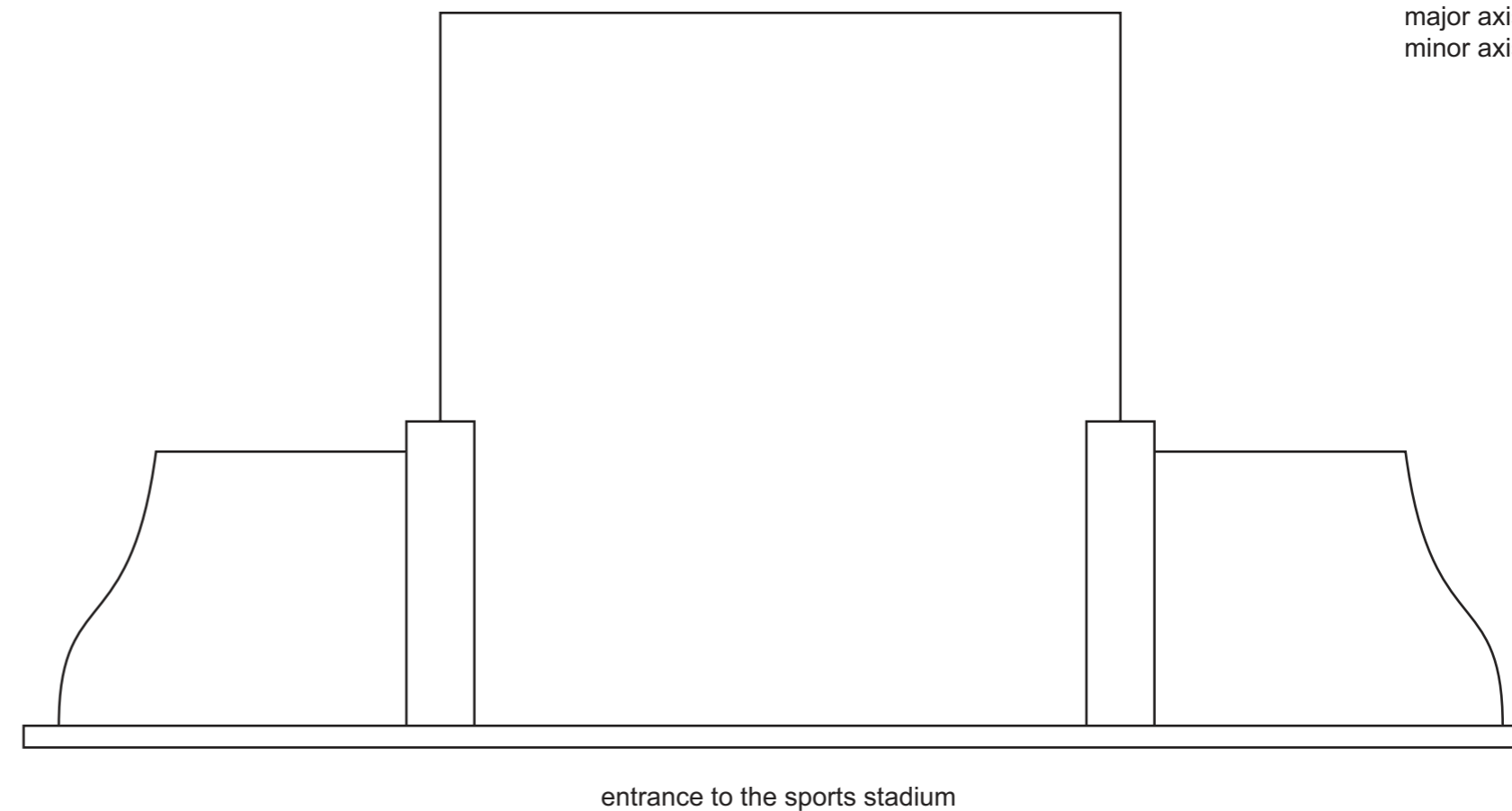
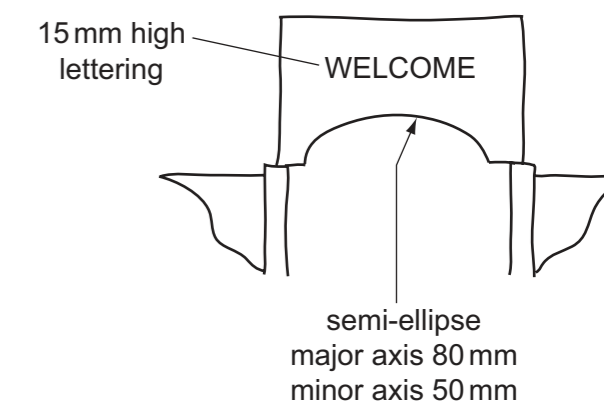

(c) A flag with a logo is added to each corner of the model of the sports stadium. The design for the logo is based upon the three geometrical shapes shown below **and** the letter 'P'.



In the space below, use sketches to show a design for the logo. [3]

(d) A pictorial view of the flag and logo is required. Complete the illustration below by:

- (i) adding the design you produced in (c); [3]
- (ii) shading the pole. [2]

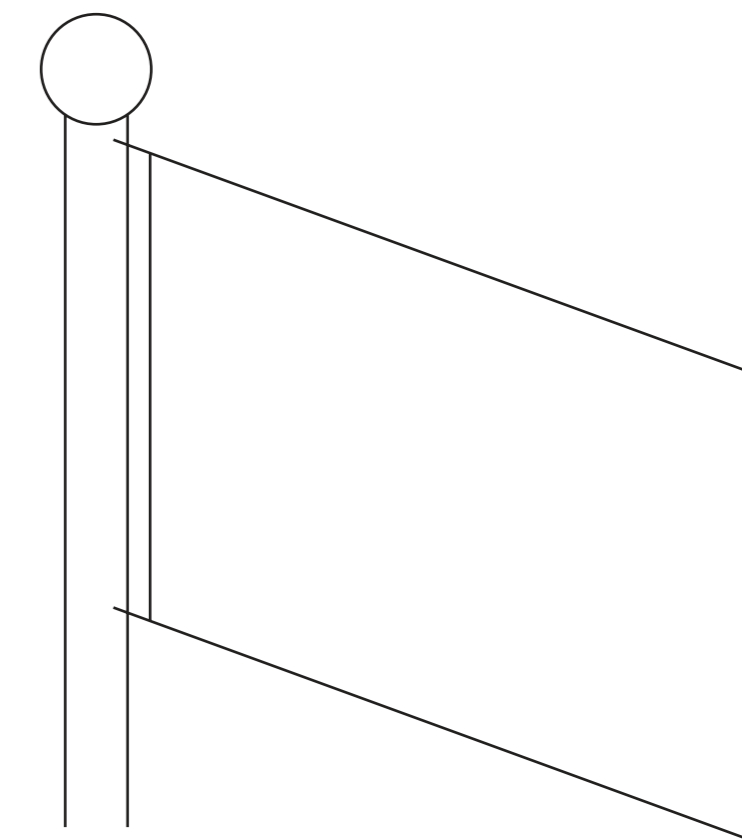

[Turn over]

Question 2

The drawing on the right shows details of a seating area for a model of a sports stadium. The model is made from card and has a detachable roof and advertising board.

(a) In the space below draw, to a scale of 1:2, the following orthographic views of the fully assembled seating area:

- (i) an end view in the direction of EE; [6]
- (ii) a front view in the direction of FE; [5]
- (iii) a plan in the direction of P. [4]

Estimate any dimensions not given.

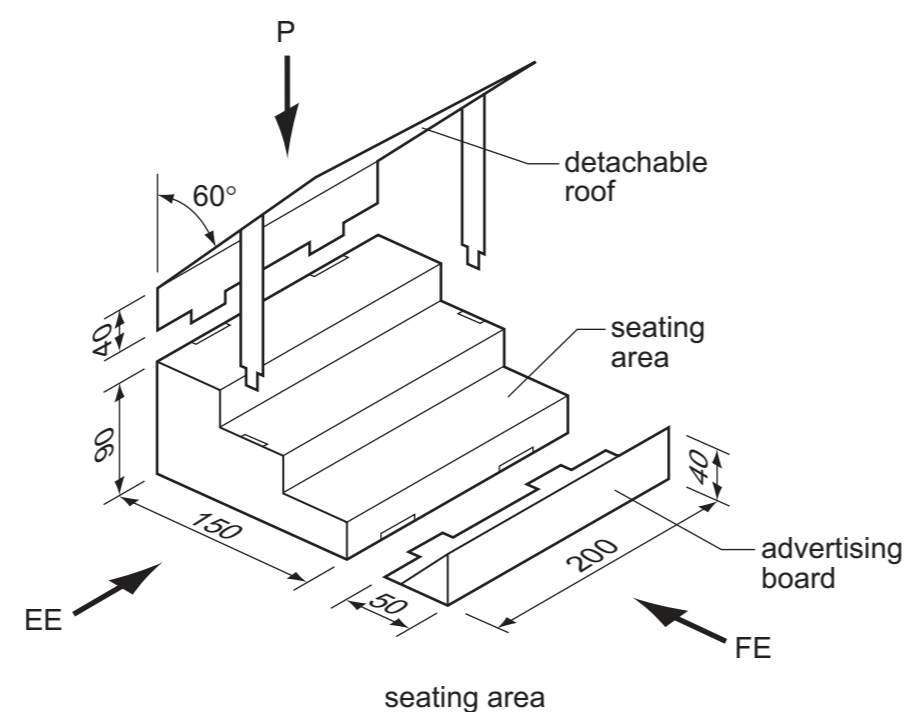

(b) Use the start lines below to complete the 1:2 scale drawing of the development (net) required to make the advertising board. Clearly show all fold lines and tabs. [5]

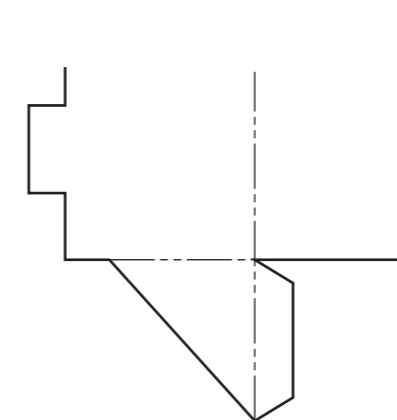

(c) An advertisement for a fruit drink is to be used on the advertising board. The design is to be based upon the images below **and** the word 'ZING'. [3]



In the space below, use sketches to show a design for the advertisement that will include at least one of the images and the word. [3]

(d) A pictorial illustration of the advertising board is required. Complete the estimated two point perspective drawing below by:

- (i) drawing the assembled advertising board; [3]
- (ii) adding the design you produced in (c); [2]
- (iii) using colour to enhance the appearance of the illustration. [2]

VP1 _____ VP2



SECTION 2: Answer **two** questions from this section.

Question 3

The sketch on the right shows the layout for a programme for a school sports day. The programme is printed on A4 paper and folded in to three equal parts.

- (a) Complete the scale 1:2 drawing below to show the layout for the programme. [12]

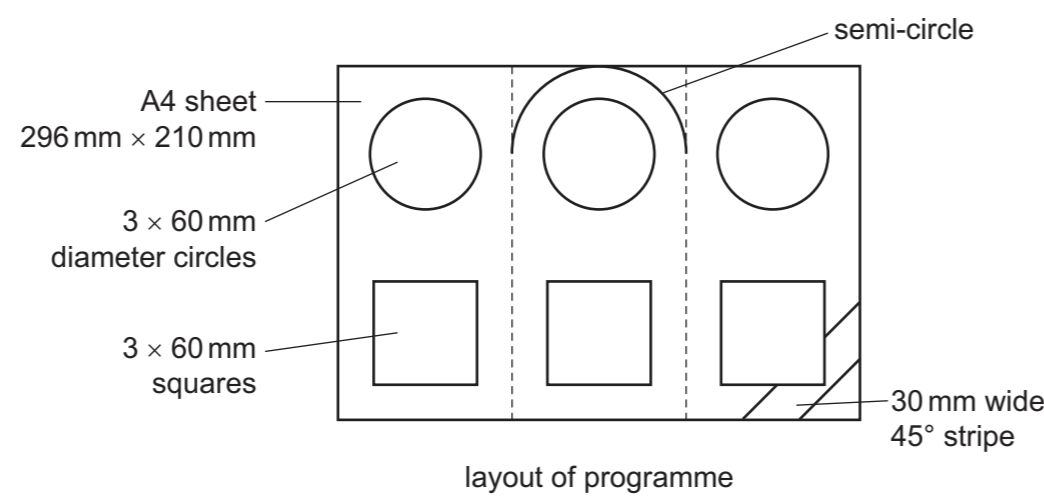

scale 1:2 drawing of programme

Question 4

The sketch below shows a sunshade that is to be used at a sports day. The sunshade has a canvas top, wooden frame and plastic base. The wooden frame consists of a central pole and arms.

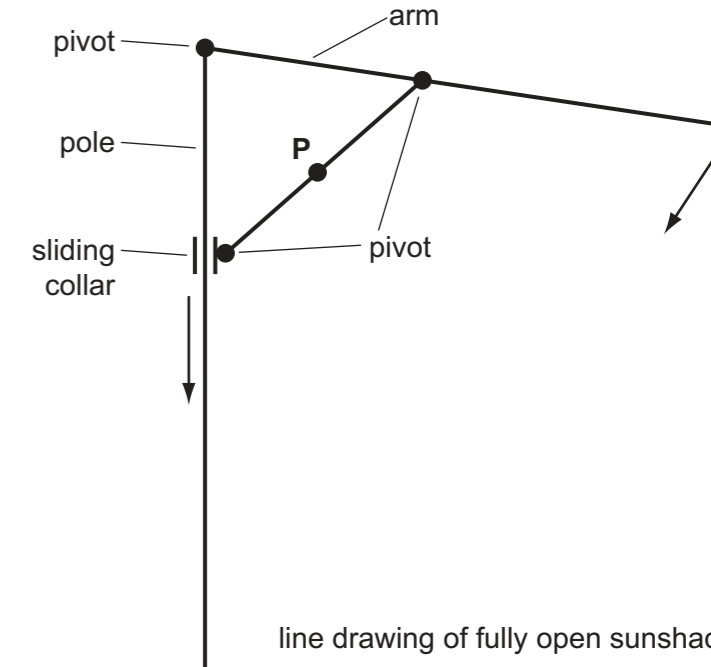
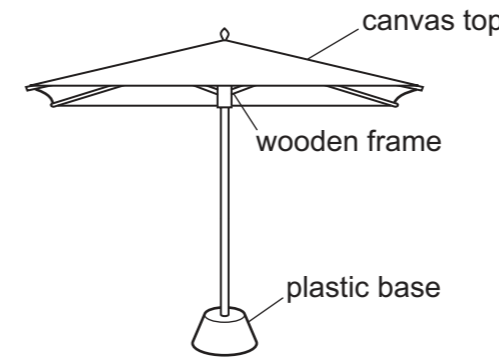

A line drawing of the pole and one arm is shown on the right.

- (a) Complete the drawing to show the path of point P as the collar slides down the pole to close the sunshade. [6]

- (b) The sliding collar is held in the fully open position by a pin.

- (i) In the space below use a pictorial sketch to show a design that uses a pin to hold the sunshade in the fully open position. [3]
 (ii) In the space on the right produce a sectional sketch of your design. [5]

A clear acrylic base is to be used to hold the programme in a triangular shape so that it can stand on a desk.

- (b) Complete the instructions below to show how the acrylic base is folded into the shape shown in stage 3. [6]

Stage 1	Cut acrylic to shape and mark out folds — cut line - - - - - fold line	
Stage 2	Fold acrylic at 90°	
Stage 3	Fold to form an equilateral triangle	

A two part wooden former is to be produced so that 50 identical acrylic bases can be made. A sectional view of the former is shown below.

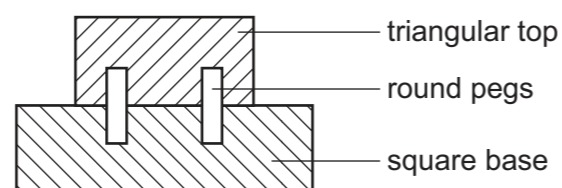

- (c) In the space below, produce an exploded pictorial sketch of the former. [7]



- (c) The pole is made from polished wood with a brass end cap. Render the drawing below to show the materials used for the pole and end cap. [6]

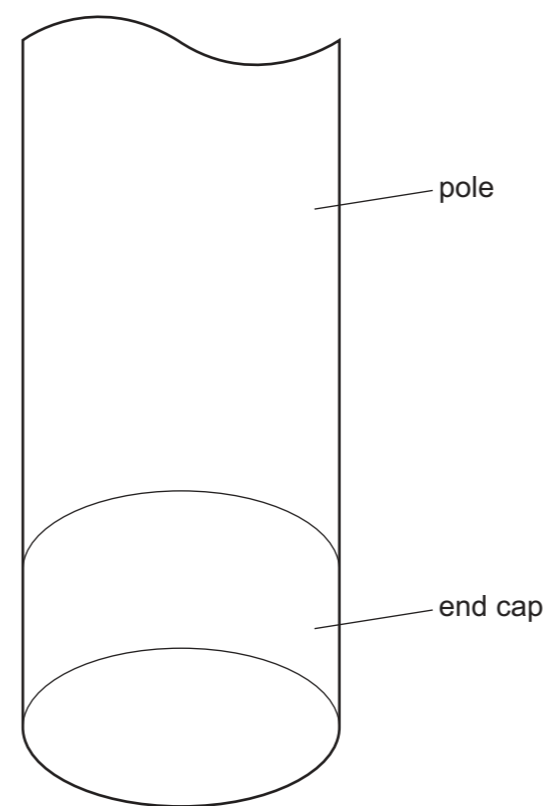

- (d) A sketch of the plastic base for the sunshade is shown below.

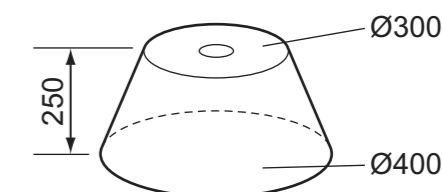

- Draw an accurate 1:10 scale planometric view of the base on the given centre lines. [5]

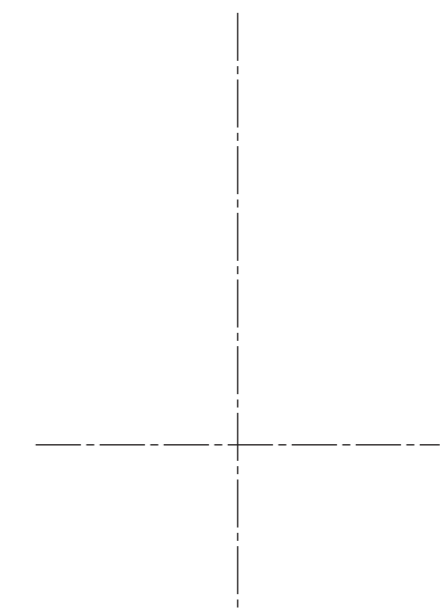

[Turn over]

Question 5

A flow chart is required to show competitors at a sports day the things they must do in order to compete. They are:

- register for sports day
- change into kit
- wait in competitor area
- check race list for your event
- compete in race
- collect certificate

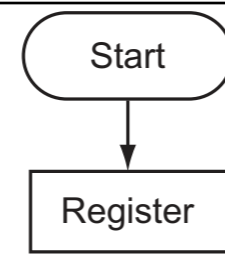

(a) In the space on the right, complete the flow chart to show competitors what they need to do. The flow chart should include a feedback loop. [9]

The following symbols are to be used in the flow chart.

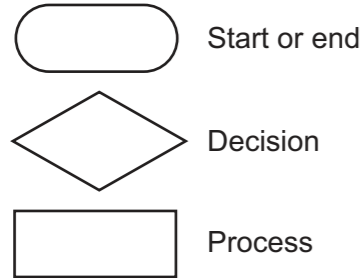

(b) Competitors are given drinking water in two types of cup. Orthographic views of the cups are shown below. On the tray shown sketch:

- (i) an isometric view of the plastic cup at position A; [3]
- (ii) a modification to the tray to hold a paper cup full of water at position B; [2]
- (iii) an isometric view of a full paper cup at position C. [3]

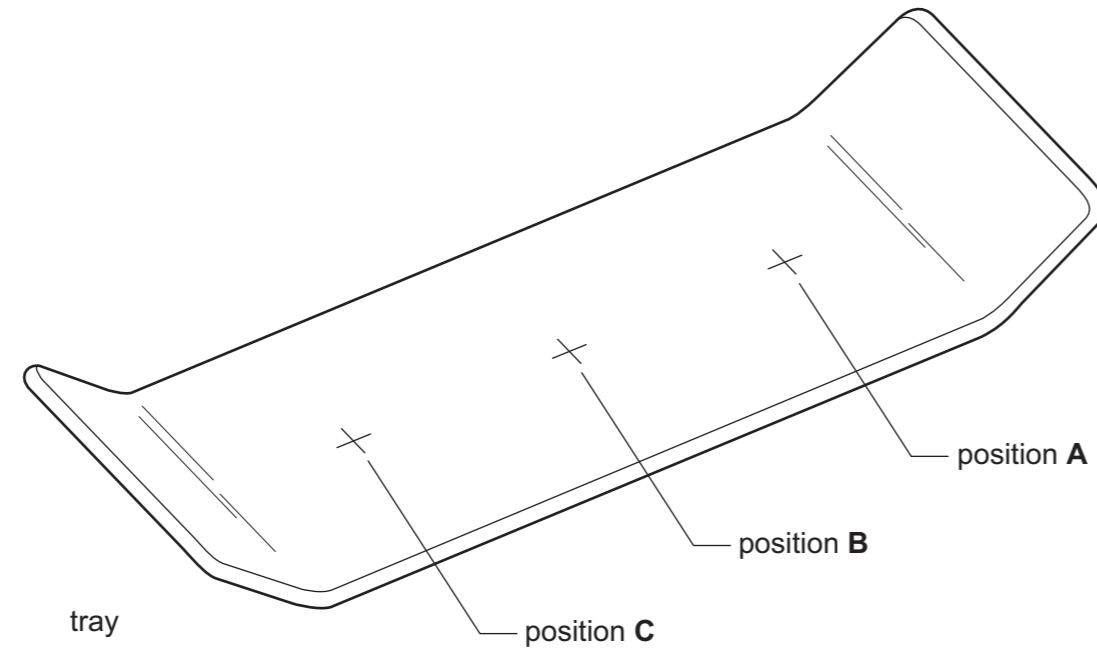
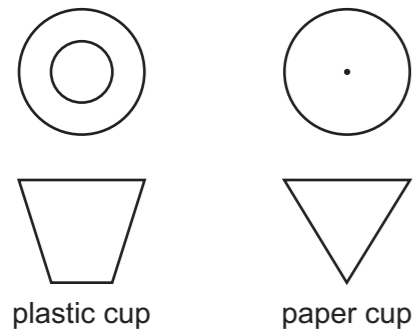

(c) A logo is required to show that the used cups must be placed in separate bins for recycling.

- (i) Use the space below to develop an idea for the logo. [4]
- (ii) Draw the logo in the box on the right. [4]



logo

idea

Question 6

Three teams are to take part in a sports day. The teams are called Lions, Eagles and Sharks. Team members are identified by an A4 sheet of paper pinned to their shirt. The paper has a border, image and the team name printed on it.

(a) Complete the drawings on the right to show the A4 paper identifying each team. The images below have been provided to help you. [8]

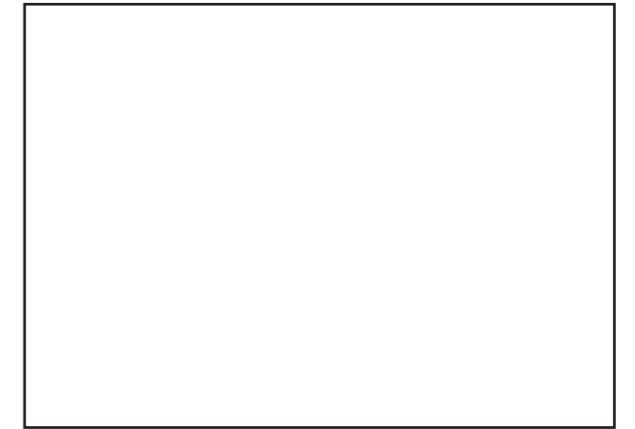
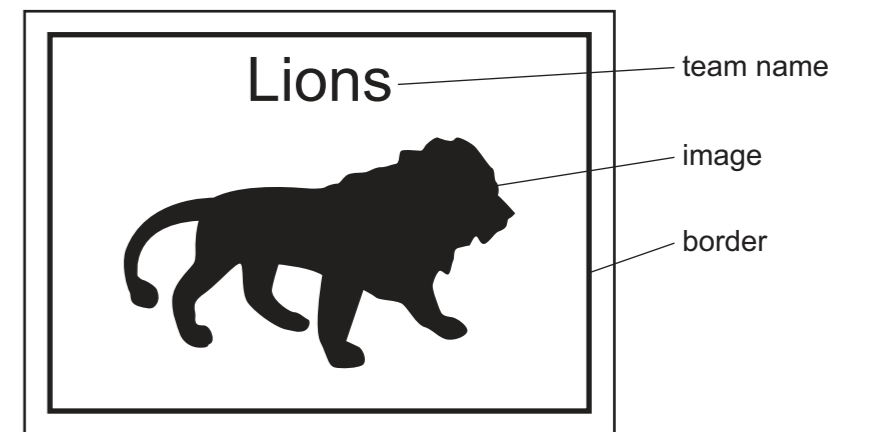
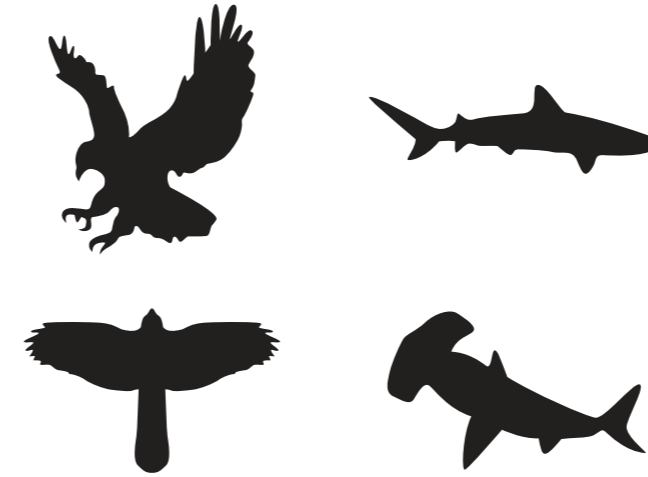

The sports day results are shown in the table below.

	First	Second	Third
Lions	6	10	2
Eagles	8	4	6
Sharks	4	4	10

(b) Use the sports day results to draw a pie chart in the circle below to show the number of first places achieved by each team. Use colour and images to enhance your chart. [8]

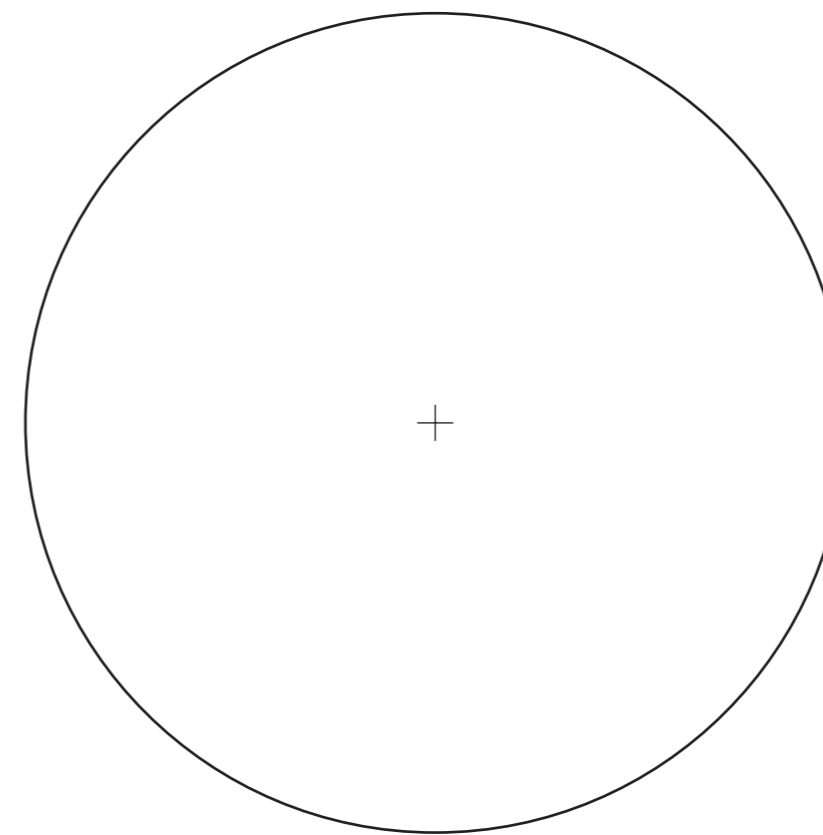

(c) Use the sports day results to draw a three dimensional bar chart to show the results of the Lions team. The chart should show the number of first, second and third places. [9]